

Gearless Machine Room Less (MRL)
Electric Traction Lifts



General Specifications

Rated load		kg	320	450	630	800	1000	1250	1350	1600
Rated speed		m/s	1 m/s and 1.6 m/s							
Type of doors			Side opening or centre opening doors							
Clear door opening		mm	700-800-900-1000-1100				900-1000-1100-1300-1400-1500-1600			
Car entrances			1 entrance or 2 entrances at 180° (no option for two entrances at 90°)							
Type of hoist machine			Gearless direct drive, permanent-magnet synchronous motor. 2:1 roping. Rescue system included.							
Hoist machine model	1 m/s		G-450	G-630	G-1,000		G-1,250	G-1,600		
	1.6 m/s									
Motor power	1 m/s	kW	3.3	4.6	7.3		9.2	11.7		
	1.6 m/s		5.3	7.4	11.7		14.7	18.8		
Number of ropes			4 ø 6.5	5 ø 6.5	6 ø 6.5		8 ø 6.5	10 ø 6.5		
Rope type			6.5 / 4.8 SDR							
Empty car total weight	1 m/s	kg	500	600	750	825	1000	1250		
	1.6 m/s		1000		1300		1650	1900		
Car guiderails	1 m/s		T-82/A		T-90/A		T-125/B			
	1.6 m/s		T-90/B		T-125/B		T-125/B	T-127/B		

Design dimensions for side-opening doors and centre-opening doors

Persons	Rated Load	Doors Size			Car internal			Recommended Shaft Size			Headroom height		Pit depth	
					Width	Depth	Height	Width	Depth		1 m/s	1.6 m/s	1 m/s	1.6 m/s
		Type	(mm)	(mm)	(mm)	(mm)	(mm)	(mm)	(mm)	(mm)	(mm)	(mm)	(mm)	(mm)
			Clear opening	HPL	AC	FC	HC	AH	FH	FH	HUP	HUP	Pit depth	Pit depth
4	320	TT	700	2000	825	1100	2100	1400*	1475	–	3400	3600	1000	1150
		CC	700	2000	825	1100	2100	1600	1400	–	3400	3600	1000	1150
6	450	TT	800	2000	1000	1200	2100	1580*	1575	1760	3400**	3600	1000	1150
		CC	800	2000	1000	1200	2100	1750	1525	1615	3400**	3600	1000	1150
8	630	TT	800	2000	1100	1400	2100	1680*	1775	1960	3400**	3600	1000	1150
			900	2000	1100	1400	2100	1680	1775	1960	3400**	3600	1000	1150
		CC	800	2000	1100	1400	2100	1750	1700	1815	3400**	3600	1000	1150
			900	2000	1100	1400	2100	1950	1700	1815	3400**	3600	1000	1150
10	800	TT	900	2000	1350	1400	2100	1950*	1800	1960	3400**	3600	1000	1150
			1200	1600	2100	1800	2000	2160						
		CC	900	2000	1350	1400	2100	1950	1725	1815	3400**	3600	1000	1150
			1200	1600	2100	1950	1900	2015						
13	1000	TT	1000	2000	1100	2100	2100	1800	2500	2660	3400**	3600	1000	1150
			1400	1600	2100	2000*	2000	2160						
		CC	1000	2000	1100	2100	2100	2150	2425	2515	3400**	3600	1000	1150
			1400	1600	2100	2150	1900	2015						
16	1250	TT	1100	2100	1350	2100	2200	2150	2500	2660	3700	3850	1150	1250
		CC						2375		2515				
18	1350	TT	1100	2100	1400	2100	2200	2200	2500	2660	3700	3850	1150	1250
		CC						2375		2515				
21	1600	TT	1100	2100	1400	2400	2200	2200	2800	2960	3700	3850	1150	1250
		CC						2375		2815				

Note: **DOORS RESTING**
 · Landing doors resting completely inside the shaft.

OPTIONAL (Consult Orona):
 * Shaft width (AH) can be reduced by 120 mm in relation to specified dimensions
 ** Headroom (HUP) for 1m/s lift, can be reduced to 3000 mm. (Compensating measures required).

Gearless Machine Room Less (MRL) Electric Traction Lifts

With two panels side-opening doors 1.0m/s

NEW **ORONA**tds™

Shaft side view

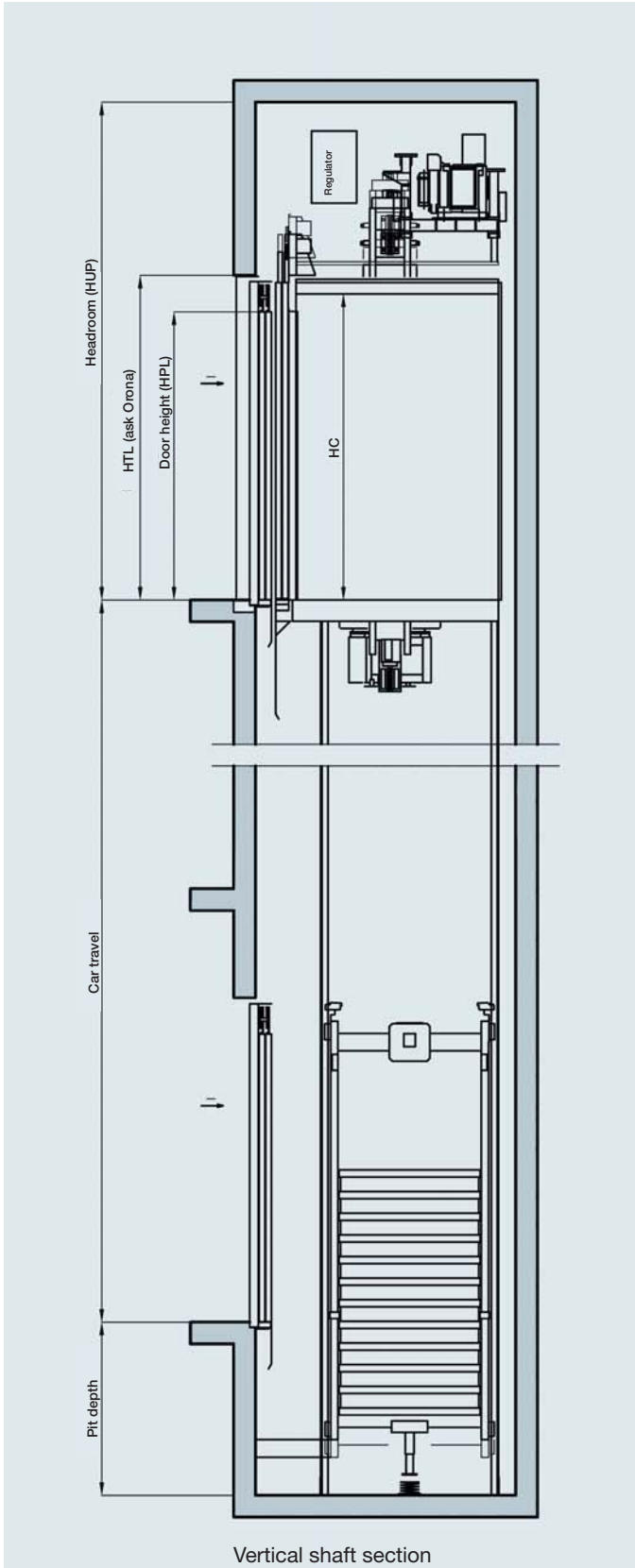

Plan view of shaft

